

GasMultiBloc® Combined regulator and safety valve Gas-air-ratio-control

DUNGS®
Combustion Controls

MBC-300-VEF
MBC-700-VEF
MBC-1200-VEF

7.03

- Max. operating pressure
360 mbar (36 kPa)
- Compact design
- High flow values
- Low weight
- Low power consumption
- Modulating mode
- Adjustable outlet pressure up
to 300 mbar (30 kPa)
- Other available servo pres-
sure regulator models:
 - zero pressure
 - constant pressure
- Mountable accessories
 - Pressure switch
 - VPS
- Ratio $V = p_{Br} / p_L = 0.4:1 \dots 3:1$
- Zero point correction possible
- Internal pulse line p_{Br}



Technical Description

The DUNGS multiple actuator MBC...VEF offers filter, valves and servo pressure regulator in one compact unit:

- Dirt trap: microfilter
- 2 solenoid valves up to 360 mbar (36 kPa) as per DIN EN 161 class A group 2
- Servo pressure regulator as per DIN EN 88 class A group 2; EN 12067-1
- Fine setting of gas and air pressure ratio
- Flange connections with pipe threads as per ISO 7/1 or NPT
- Easy to install
- Low weight

As this system has a modular design, we can offer individual solutions with valve inspection system, pressure switches mini/ maxi and pressure limiters. High flow values at low pressure difference.

Application

The servo pressure regulator permits optimum mixture formation in forced air burners and premix burners; this applies to modulating and multi-stage variable operating modes.

Suitable for gases of gas families 1, 2, 3 and other neutral gaseous media.

Approvals

EC type testing certificate as per:

- EC-Gas Appliances Regulation
 - EC-Pressure Equipment Directive
- Approvals in other important gas-consuming countries.

Functional Description

Gas flow

1. If the V1 and V2 valves are closed, chamber a is under inlet pressure.
2. The min. pressure switch (option) is connected to chamber a via a bore-hole.

If the inlet pressure exceeds the reference value set in the pressure switch, the switch switches through to the automatic burner control.

3. The V1 and V2 valves open after they are enabled by the automatic burner control.

Gas flow through the chambers a and b is enabled.

Functional description of the valve-regulator combination

Valves V1 and V2 can be controlled electrically and independent of each other. Each valve pretensions its own pressure spring when the plunger opens. If both valves are open, a pressure pulse is sent under the working diaphragm M. The intensity of this pressure pulse changes depending on the adjustable restrictor point D.

The comparison diaphragms S_1 for burner pressure p_{Br} and S_2 for blower pressure p_L are connected with each other via a rod. The ratio V can be set by shifting the bearing point.

Zero point correction N acts on this rod mechanism via the air diaphragm S_2 . Ambient pressure p_{amb} or firing chamber pressure p_F must be applied to the area between the comparison diaphragms. The firing chamber pressure reduces the burner pressure at a ratio of $V > 1$. Changes in the equilibrium of forces result in a change in the flow cross-section.

The pressure under the working diaphragm is re-adjusted. The regulator unit adapts the free valve cross-section depending on the new flow requirement.

Closing function

If the supply voltage of the solenoid coils of V1 and V2 valves is interrupted, the pressure springs close the valves in $<1s$.

Block diagram MBC...VEF

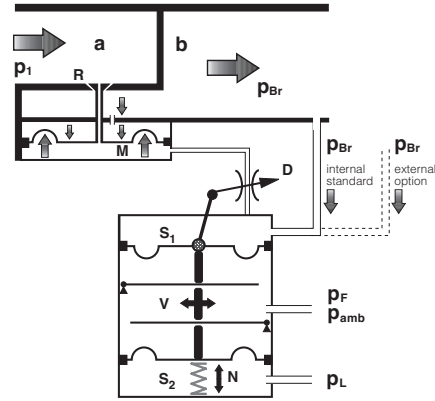

M	Working diaphragm	a, b	Pressure chambers in flow direction
D	Restrictor		
S1	Servo diaphragm for burner pressure p_{Br}	p_1	Inlet pressure
S2	Servo diaphragm for blower pressure p_L	p_{Br}	Burner pressure, outlet pressure:
R	Regulator disc	p_{amb}	Ambient pressure
		p_L	Blower pressure

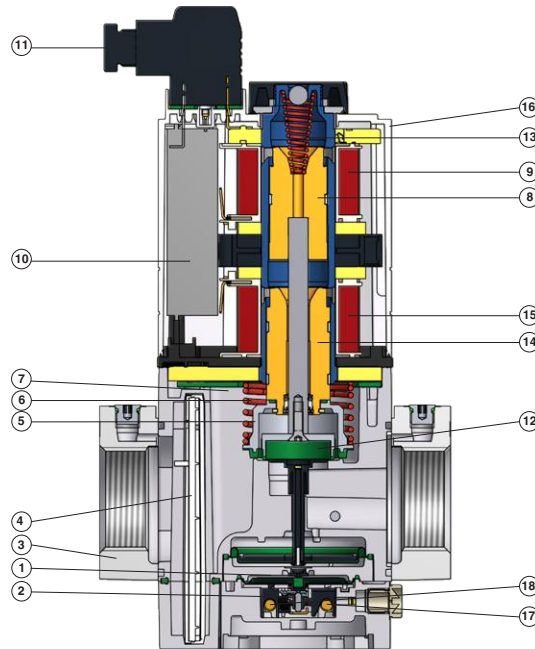

1	Pressure regulator unit	8	Plunger V1	15	Solenoid V2
2	Regulator spring	9	Solenoid V1	16	Solenoid housing
3	Connecting flange	10	Printed circuit board	Setting:	
4	Micro-filter	11	Electrical connection	17	Gas-air ratio
5	Valve V1	12	Valve V2	18	Zero point correction
6	Closing spring V1	13	Closing spring V2		
7	Housing	14	Plunger V2		

Pressure taps, gas train diagram MBC...VEF

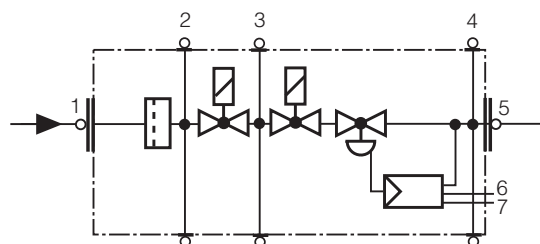

1, 2, 3, 4, 5	Screw plug G 1/8
6, 7	Seal plug G 1/8

Technical Data

Nominal widths Flanges with pipe threads according to ISO 7/1 (DIN 2999)	MBC-300-VEF Rp 1/2, 3/4, 1, 1 1/4 and their combinations	MBC-700-VEF Rp 1, 1 1/4, 1 1/2, 2 and their combinations	MBC-1200-VEF Rp 1, 1 1/4, 1 1/2, 2 and their combinations
Max. operating pressure Inlet pressure range Guiding range Burner pressure range	360 mbar (36 kPa) p_e : 15 mbar (1.5 kPa) to 360 mbar (36 kPa) p_L : 0.4 mbar (0.04 kPa) to 100 mbar (10 kPa) p_{Br} : 0.5 mbar (0.05 kPa) to 100 mbar (10 kPa)		
Media	Gases of gas families 1, 2, 3 and other neutral gaseous media.		
Ambient temperature	-15 °C to +70 °C (do not operate MBC...VEF below 0 °C in liquefied gas systems. Only suitable for gaseous LPG; liquid hydrocarbons destroy the seal materials)		
Dirt trap device	Micro-filter made of chopped-strand nonwoven fabric. Filter replaceable without removing fitting		
Pressure switch	The system can be equipped with pressure switch types GW A5, NB A2, ÜB A2 as per DIN EN 1854. For further information, refer to data sheets "Pressure switch for DUNGS multiple actuators" 5.02		
Servo pressure regulator	Servo pressure regulator with adjustable burner pressure, as per DIN EN 88 class A, group 2; EN 12067-1 Gas-air ratio control with adjustable ratio V as well as correction of zero point N and firing chamber pressure connection		
Ratio setting range V	Ratio V = p _{Br} / p _L = 0.4:1... 3:1, other ratios on request		
Zero point correction N	possible		
Solenoid valve V1, V2	Valves as per DIN EN 161 class A group 2; fast closing, fast opening		
Measuring gas connection	G 1/8 DIN ISO 228, at inlet and outlet flanges, on both sides downstream of filter, between V1 and V2, downstream of V2 (fitting the pressure switch may partially exclude measuring gas connection)		
Burner pressure monitor p _{Br}	Downstream of valve V2, pressure switch can be mounted on the side of the adapter		
Pulse and connection lines	G 1/8 connection as per DIN ISO 228 for burner pressure (p _{Br} ; GAS), blower pressure (p _L ; AIR), firing chamber pressure (p _F ; combustion, atmosphere) Pulse and connection lines must be made of steel and conform to PN1, DN4. Condensate of pulse and connection lines may not enter the fitting. Strictly follow the operating and mounting instructions.		
Voltage/frequency	~(AC) 50 - 60 Hz 230 V -15 % +10 %, other voltages on request. Other preferred voltages: ~(AC) 100 V - 120 V, =(DC) 24 V - 28 V		
Electrical connection	Plug-in connection as per DIN EN 175301-803 for valves		
Rating / power consumption Switch-on duration Switching cycles Degree of protection Radio interference suppression	at ~ (AC) 230 V; +20 °C: see type overview 100 % duty 60 per hour (30 s on/off) IP 54 as per IEC 529 (EN 60529) Interference level N		
Materials of gas-conveying parts	Housing Diaphragms Solenoid drive	die-cast aluminium NBR basis steel, aluminium	
Installation position	Vertical with upright solenoid or horizontal with horizontal solenoid, as well as their spacers		

Dimensions [mm]

MBC-300/700...VEF

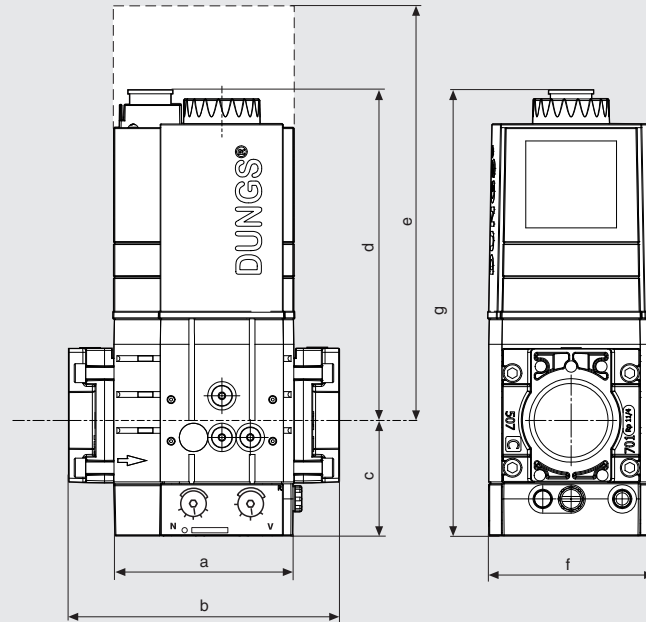

MBC-1200...VEF

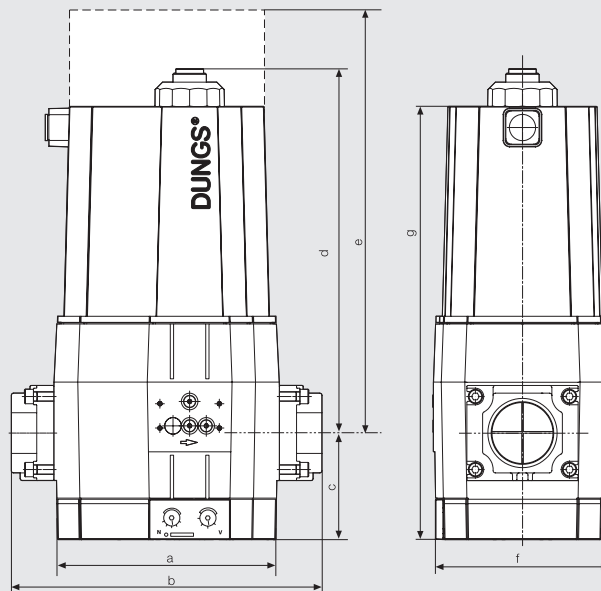

e = space required for replacing the solenoid

Mounting the pulse lines

MBC...VEF

1 p_e : gas inlet pressure
15 -360 mbar

4 p_{Br} : burner pressure, gas
0.5 -100 mbar
optional: external pulse
standard: internal pulse

6 p_F : firing chamber pressure
-20 mbar ... +50 mbar
or atmosphere

$$\Delta p_L \text{ max.} = p_L - p_F = 100 \text{ mbar}$$

$$\Delta p_{Br} \text{ max.} = p_{Br} - p_F = 100 \text{ mbar}$$

7 p_L : blower pressure, air
0.4 -100 mbar

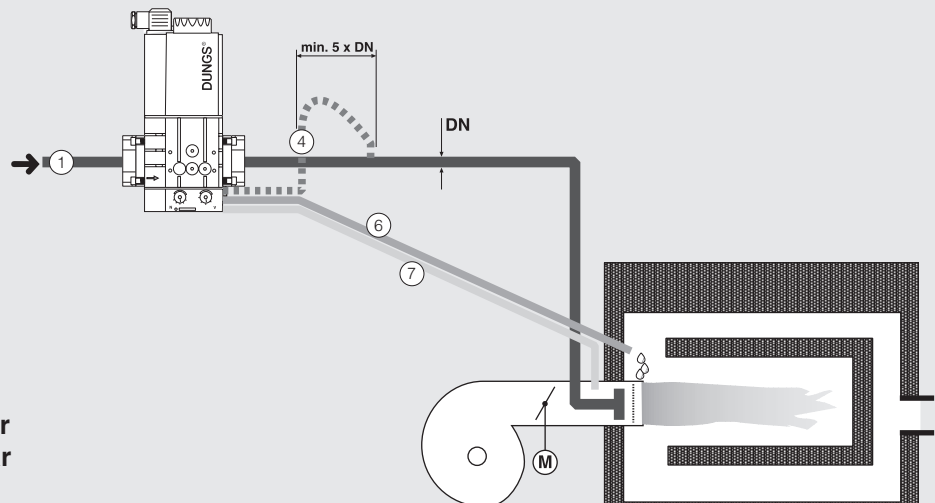

Pulse lines

 Pulse lines 4, 6, 7 must be made of steel and correspond to \geq DN 4 (diameter 4 mm), PN 1. **Other pulse lines materials are permissible as per type test together with the burner.**

 Route pulse lines in such a way that **no condensate** can flow into the MBC...VEF.

 Route pulse lines in such a way that they are protected against cracks and deformation. **Keep pulse lines short.**

Type Version	Order no. 230 VAC	DN Rp	Opening time	Dimensions [mm]							Solenoid Switch- no.	Weight [kg]	
				a	b	c	d	e	f	g			
MBC-300-VEF	261 653	1/2 - 1 1/4	< 1 s	95	143	61	175	297	87	236	032/2P	60	3.6
MBC-700-VEF	261 654	1 - 2	< 1 s	126	176	80	187	310	114	267	042/2P	60	5.1
MBC-1200-VEF	243 413	1 - 2	< 1 s	204	281	96	328	530	161	424	052/P	60	16.8

$P_{\max.}$
[VA] for t = 3 s

$P_{\max.}$
[VA] operation

MBC-300-VEF	120	15
MBC-700-VEF	180	20
MBC-1200-VEF	200	30

Flange for	Rp/NPT	Order no.	Order no.
MBC-300-VEF	Rp 1/2	222 341	Line socket 3 pole + PE 210 319
MBC-300-VEF	Rp 3/4	222 342	
MBC-300-VEF	Rp 1	222 001	
MBC-300-VEF	Rp 1 1/4	240 506	
MBC-700/1200-VEF	Rp 1	222 343	Adapter, pressure gauge flange set G1/2 216 675 Adapter GW A with G1/4 222 982 Adapter p _{Br} 214 975 Adapter GW A on flange 221 630
MBC-700/1200-VEF	Rp 1 1/4	222 344	
MBC-700/1200-VEF	Rp 1 1/2	221 884	
MBC-700/1200-VEF	Rp 2	221 926	
MBC-300-VEF	NPT 1/2	222 371	 Flanges, plug-in connection and system accessories must be ordered separately.
MBC-300-VEF	NPT 3/4	222 368	
MBC-300-VEF	NPT 1	221 999	
MBC-300-VEF	NPT 1 1/4	231 718	
MBC-700/1200-VEF	NPT 1	222 369	
MBC-700/1200-VEF	NPT 1 1/4	222 370	
MBC-700/1200-VEF	NPT 1 1/2	222 003	
MBC-700/1200-VEF	NPT 2	221 997	

Gas Type of gas / specific density [kg/m ³]		
Volumetric flow V [m³/h] V _{min.} V _{max.}		
Inlet pressure p_e [mbar] p _{e,min.} p _{e,max.}		
Burner pressure p_{Br} [mbar] at V _{min.} at V _{max.}		
Blower pressure p_L [mbar] at V _{min.} at V _{max.}		
Firing chamber pressure p_F [mbar] at V _{min.} at V _{max.}		
Control range, output range		
Time taken to re-adjust air volume restrictors from small load to large load [s]		
Starting load [m³/h]		
Company / address		
Name / contact person		
Telephone		

$$f = \sqrt{\frac{\text{Air density}}{\text{Density of gas used}}}$$

$$\dot{V}_{\text{used Gas}} = \dot{V}_{\text{Air}} \times f$$

Gas type	Density [kg/m ³]	dv	f
Natural gas	0.81	0.65	1.24
City gas	0.58	0.47	1.46
Liquefied gas	2.08	1.67	0.77
Air	1.24	1.00	1.00

Volume flow pressure difference characteristics in steady state with microfilter.

MBC-300-VEF

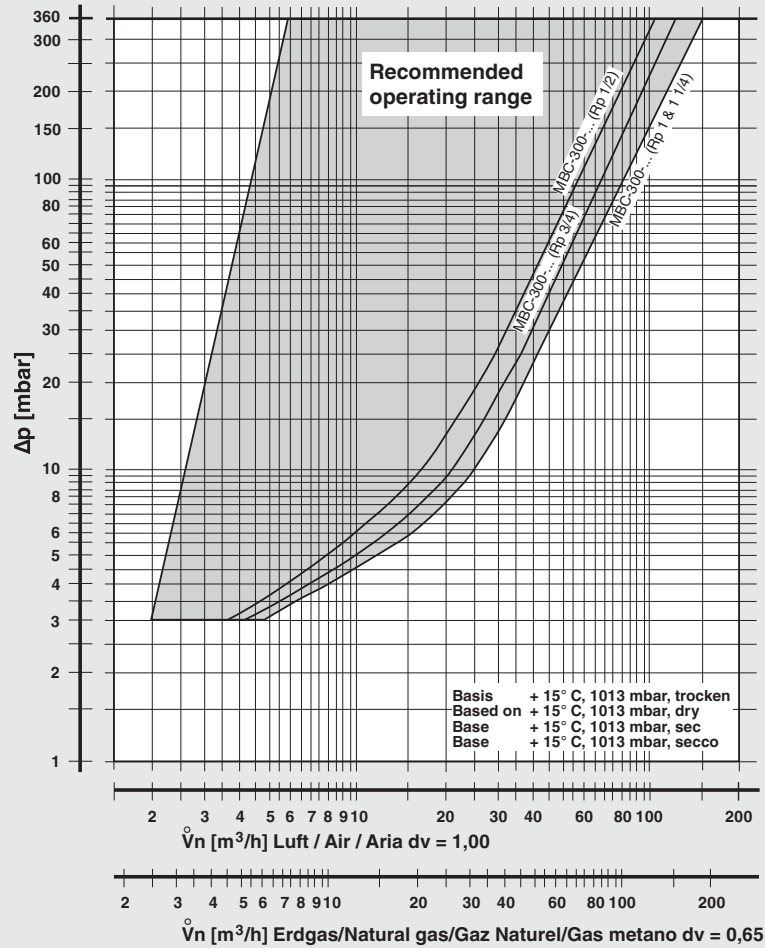

Volume flow pressure difference characteristics in steady state with microfilter.

MBC-700-VEF

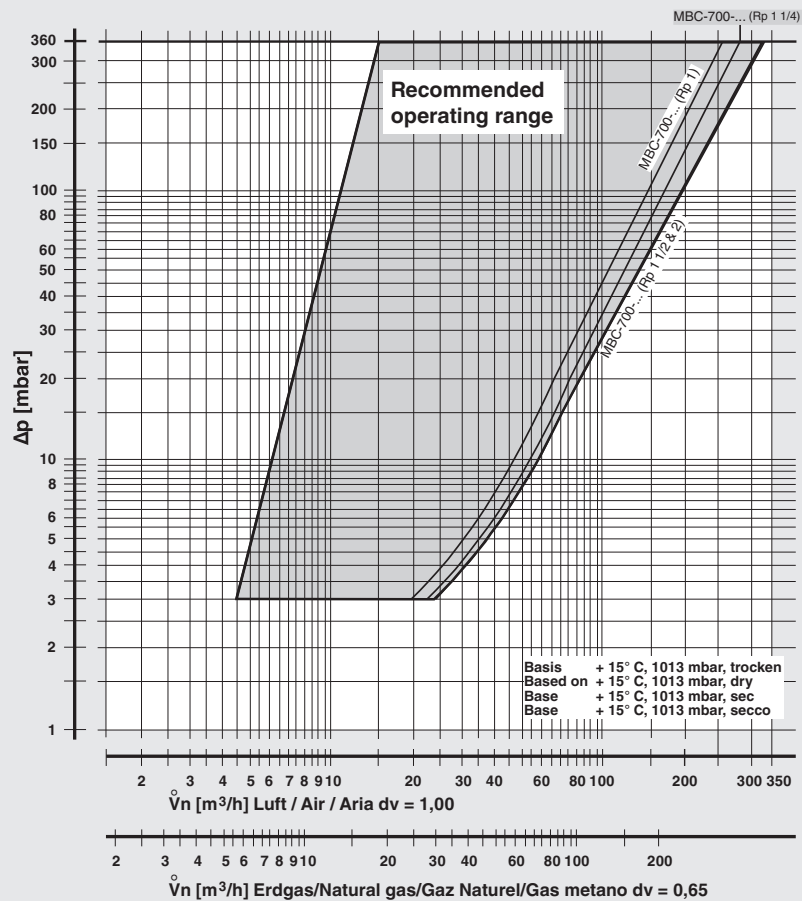

GasMultiBloc®
 Combined regulator and
 safety valve
 Infinitely variable air/gas
 ratio control mode

MBC-300-VEF
 MBC-700-VEF
 MBC-1200-VEF

DUNGS®
 Combustion Controls

Volume flow pressure difference characteristics in steady state with microfilter.

MBC-1200-VEF

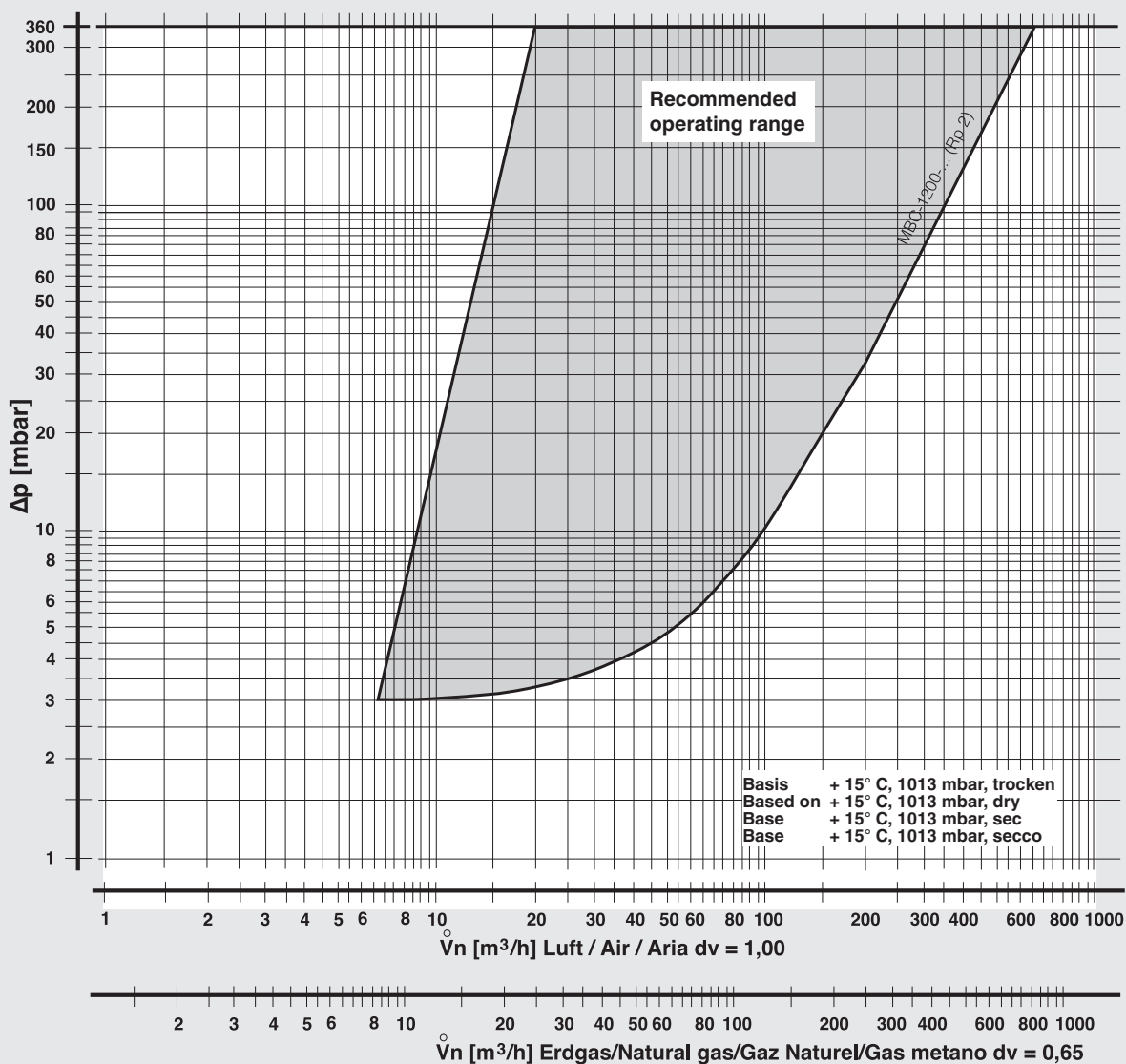

We reserve the right to make changes in the interest of technical progress.

Head Offices & Factory
 Karl Dungs GmbH & Co. KG
 Karl-Dungs-Platz 1
 D-73660 Urbach, Germany
 Telefon +49 (0)7181-804-0
 Telefax +49 (0)7181-804-166

Postal address
 Karl Dungs GmbH & Co. KG
 Postfach 12 29
 D-73602 Schorndorf, Germany
 e-mail info@dungs.com
 Internet www.dungs.com